



COLLAIRE

felt wall



HOW TO SPECIFY

Collaire turns any wall into a blank canvas with total design flexibility. Specify an array of tiles within a space and form a pattern, or go floor to ceiling for a custom architectural wall-cladding look, while also providing acoustic performance.

01 SPECS

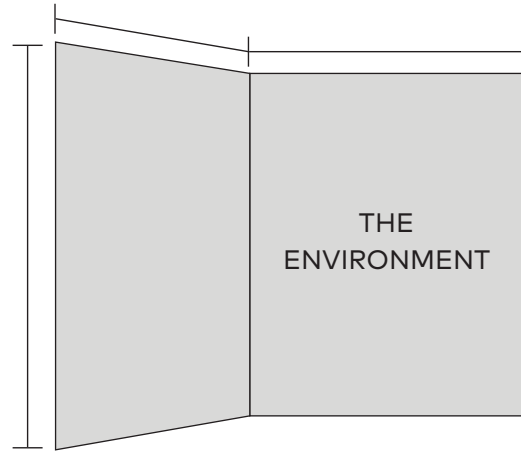

Tell us about your space, the design, and dimensions.

02 PATTERN ORIENTATION

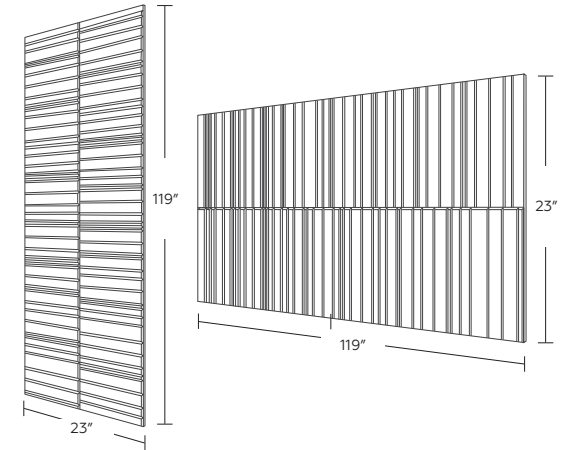

Do you need the Collaire pattern vertically or horizontally oriented?

03 COLORS

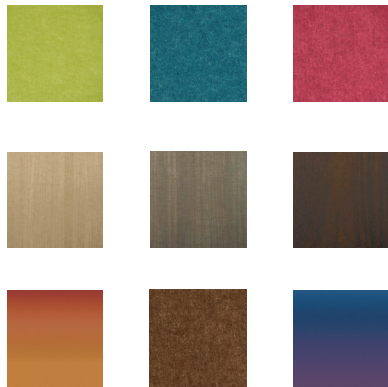

Standards. Woodgrains. Customs.
What's your color? (See page 7)

04 MAKE IT YOUR OWN!

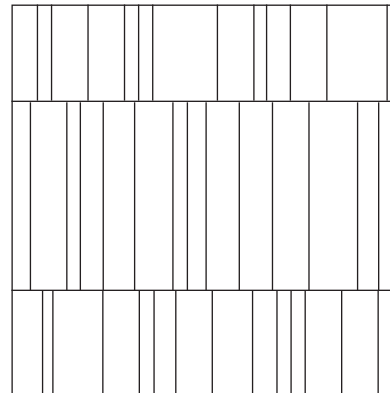

Customize your pattern

SHADES by MPS



Even more color options with SHADES by MPS. (See page 7)



PRODUCT SPECIFICATIONS

STANDARD DIMENSIONS

Single Panel 23" x 119"

Felt Thickness 3/8"

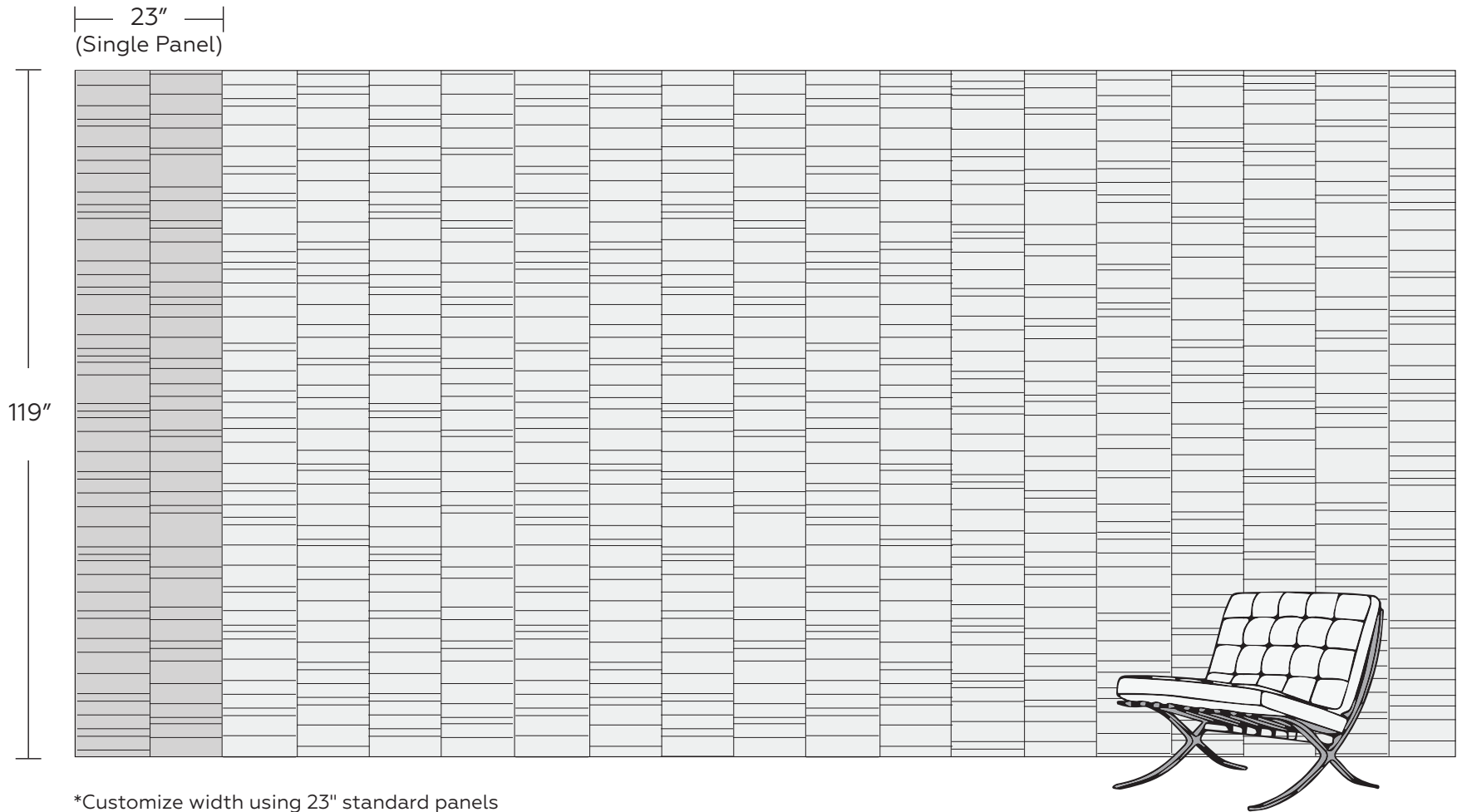

*Customize width using 23" standard panels



PRODUCT SPECIFICATIONS

PATTERN ORIENTATION

Collaire comes in both vertical and horizontal pattern layouts.

VERTICAL PATTERN LAYOUT

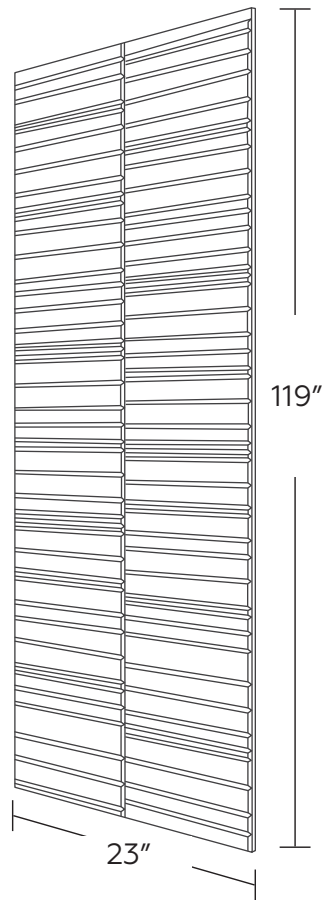

HORIZONTAL PATTERN LAYOUT

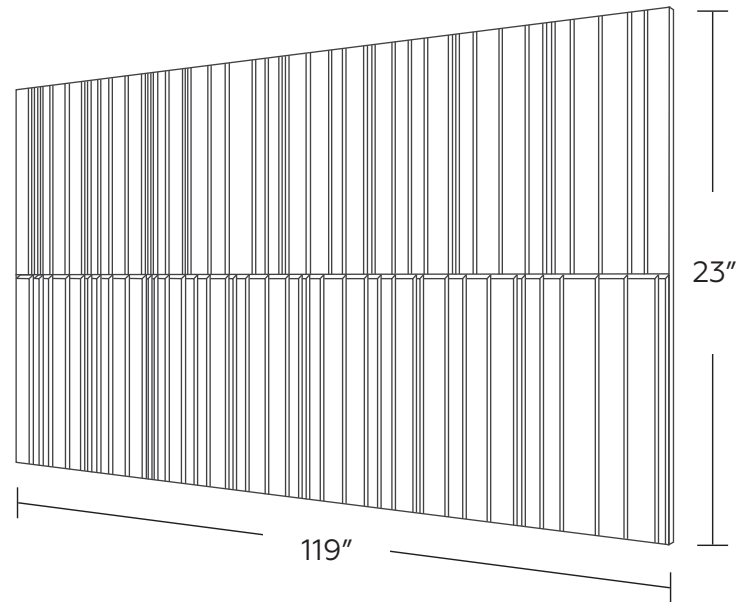



PRODUCT SPECIFICATIONS

CONNECTION

Standard Connection: Construction Adhesive
(provided by MPS)

Alternate Connection: Z-Clip
(Acoustic Enhancers Required)

"TONGUE & GROOVE" ACOUSTIC ENHANCER

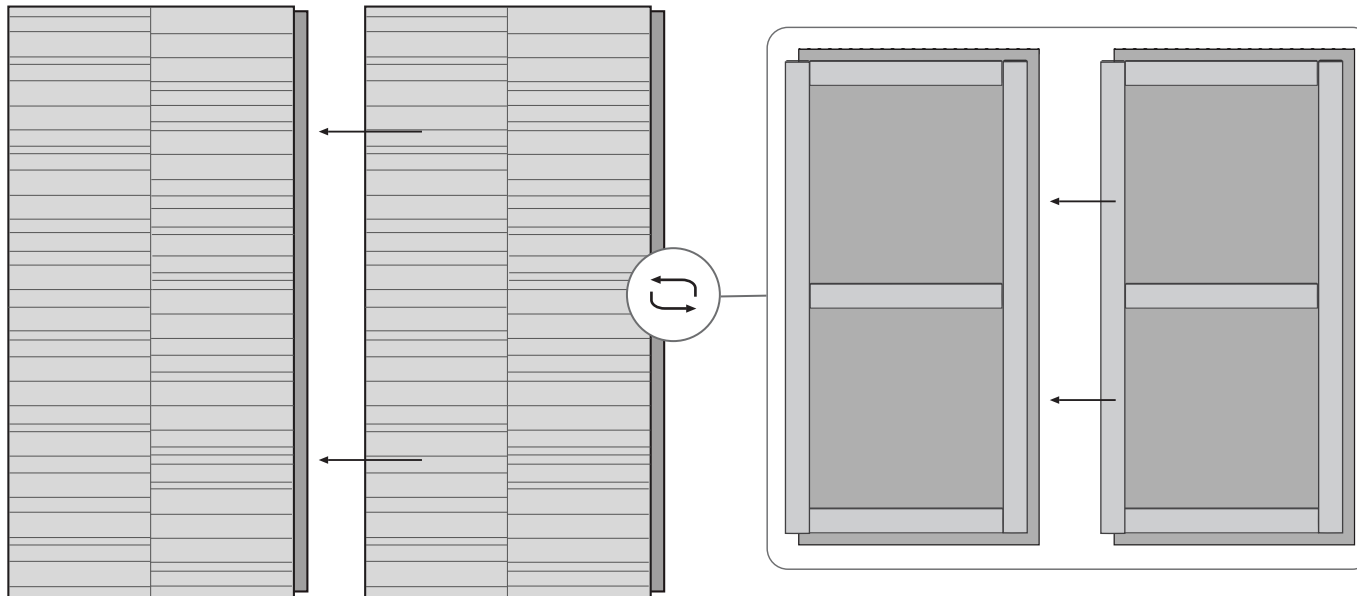



TECHNICAL SPECIFICATIONS



Absorption

Standard: .32 NRC

(subject to mounting conditions)

Fire Rating

ASTM E84 Class A

Warranty

Two (2) Years

VOC

ASTM D5116 Compliant

Material

100% PET acoustic felt

Maintenance

Vacuum clean to remove dust and debris

Sustainability



MPS 9mm Acoustic Panels
MPS LLC

Final Assembly: Plano, Texas, USA
Life Expectancy: 50 Year(s)
End of Life Options: Salvageable/Reusable in its Entirety, Take Back Program (Plano, TX), Recyclable (100%)

Ingredients:
Polyethylene Terephthalate

Living Building Challenge Criteria: Compliant

I-13 Red List:
 LBC Red List Free % Disclosed: 100% at 100ppm
 LBC Red List Approved VOC Content: Not Applicable
 Declared

I-10 Interior Performance: CDPH Standard Method v1 2-2017
I-14 Responsible Sourcing: Not Applicable

MPS-0001
 EXP. 01 NOV 2026
 Original Issue Date: 2022

MANUFACTURER RESPONSIBLE FOR LABEL ACCURACY
 INTERNATIONAL LIVING FUTURE INSTITUTE™ living-future.org/declare





COLORS & WOODGRAINS

MPS offers a range of standard colors, woodgrains, and custom colors with SHADES.

STANDARD COLORS



WOODGRAINS



SHADES by MPS™

Your design world revolves around color, so don't be limited by standard colors and outdated palettes. We've distilled years of testing into a three-tier system that protects print quality and design intent.

*Some limitations apply. Consult your MPS acoustics expert to discuss your project.

RECOMMENDED	GUIDED CUSTOM	BESPOKE
 Signature Series Proven color. Perfect results.	 Studio Collaboration Your color, guided by our expertise.	 The Color Lab When your color needs to be one-of-a-kind.



ADDITIONAL CURATED COLORS

MPS offers a range of over 50 curated colors.

LINEN AVOCADO	GLEEFUL AVOCADO	LILY PAD	BASIL	CACTUS	TAUPE SAND	TURTLE AVOCADO	DRIZZLE	ARTICHOKE MARBLE	PARADISE AVOCADO	ROSEMARY SAGE
ASSURED MARBLE	SILDEN CREAM	CLOUD SAGE	GRAND CANAL KHAKI	HUNTER OCEAN	JADE DENIM	DELFT DENIM	STORM DENIM	SKY MARBLE	DEEP GRANITE	STILL EVERGREEN
SLATE IVORY	BLUE MARBLE	MYTHICAL SAGE	PINES IVORY	GROVE IVORY	HAZE GRAPHITE	UNDERSEA GRANITE	GARDEN WINE	ACIER SLATE	RIVER GRAPHITE	ALEXANDRITE EVERGREEN
SAND BISCUIT	COCOA CREAM	STUDIO SAND	BEIGE EARTH	COBBLE BISCUIT	BRANDYWINE KHAKI	ROJO SAND	SANGRIA	FIREWEED KHAKI	AMBER COFFEE	FRENCH MARBLE
ROSE IVORY	PEACH IVORY	GOLD SAND	ROGUE CREAM	ROSE WINE	BURGUNDY WINE	REDBUD OCEAN	PRESSED SAGE	PEPPERCORN GRANITE		



MOUNTING OPTIONS

TOOLS REQUIRED



Cutting tool



Steel straightedge



Drill



Hole saw



Construction adhesive

DRY FIT

Before applying adhesive, dry fit the first panel to the wall.

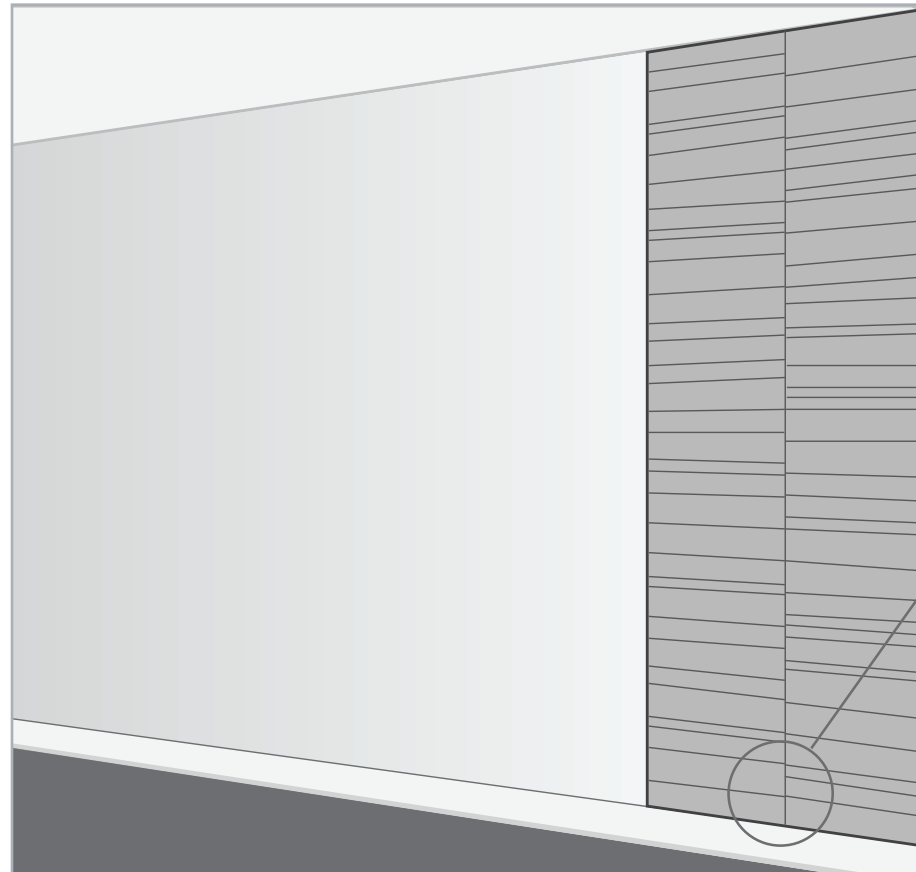

Note: to avoid irregularity, we recommend applying to the top of a baseboard.



MOUNTING OPTIONS

APPLY CONSTRUCTION ADHESIVE (RECOMMENDED)

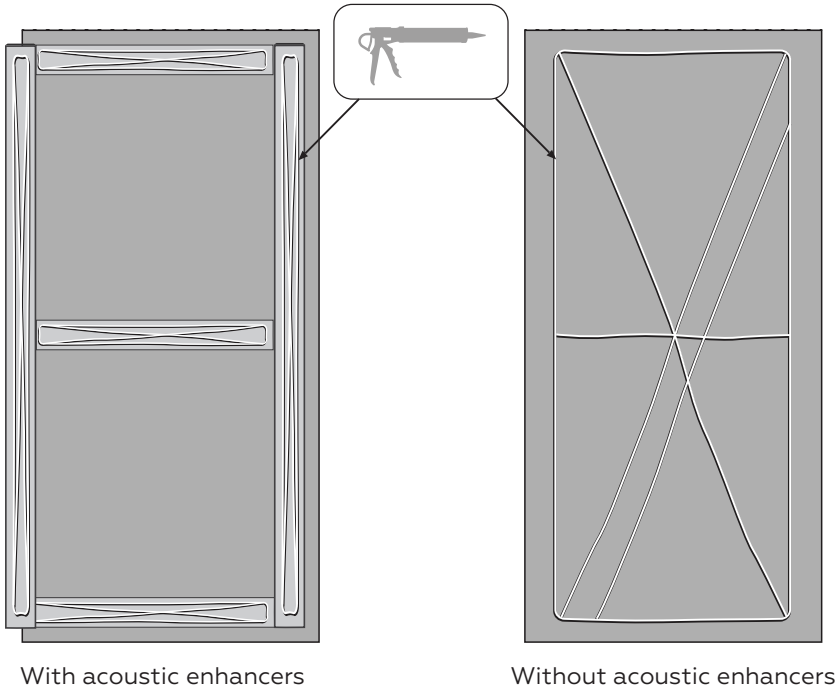

HOOK Z-CLIPS (ALTERNATIVE)

Determine the desired position of z-clips and screw them into the back of the panel.

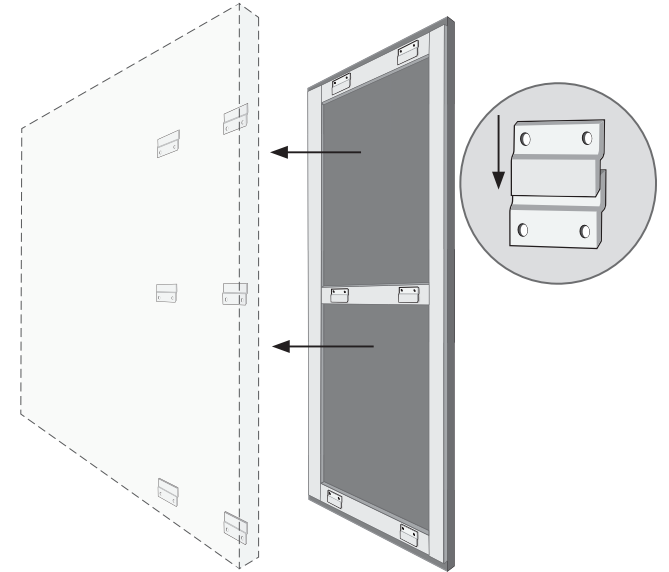

TRIM AS REQUIRED

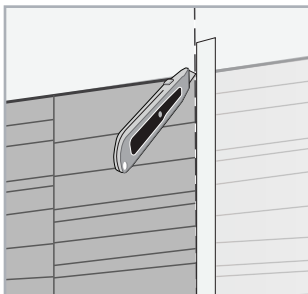

Trim panels along the end to fit using a straight edge and cutting tool.

TRIMMING HOLES

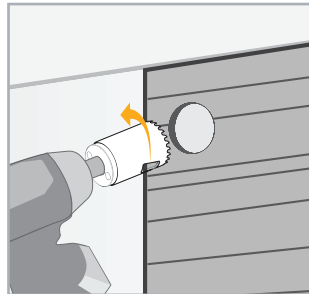

When cutting a circular hole use a hole saw, and run it backwards to minimize pulling.