



JOIST LED

felt ceiling baffle



JOIST LED CEILING-MOUNTED BAFFLES

Welcome to the installation guide for Joist LED, a minimal and versatile acoustic ceiling baffle designed for both functionality and aesthetics. This guide will walk you through the easy-to-follow steps to securely mount Joist LED using cable grippers, ensuring optimal acoustic performance and seamless integration into your space.

Installers should rely upon their own professional experience and understanding of their unique requirements to ensure a successful install.

TOOLS REQUIRED



Level



Screwdriver



Cable Strippers

COMPLETED VIEW OF ASSEMBLY

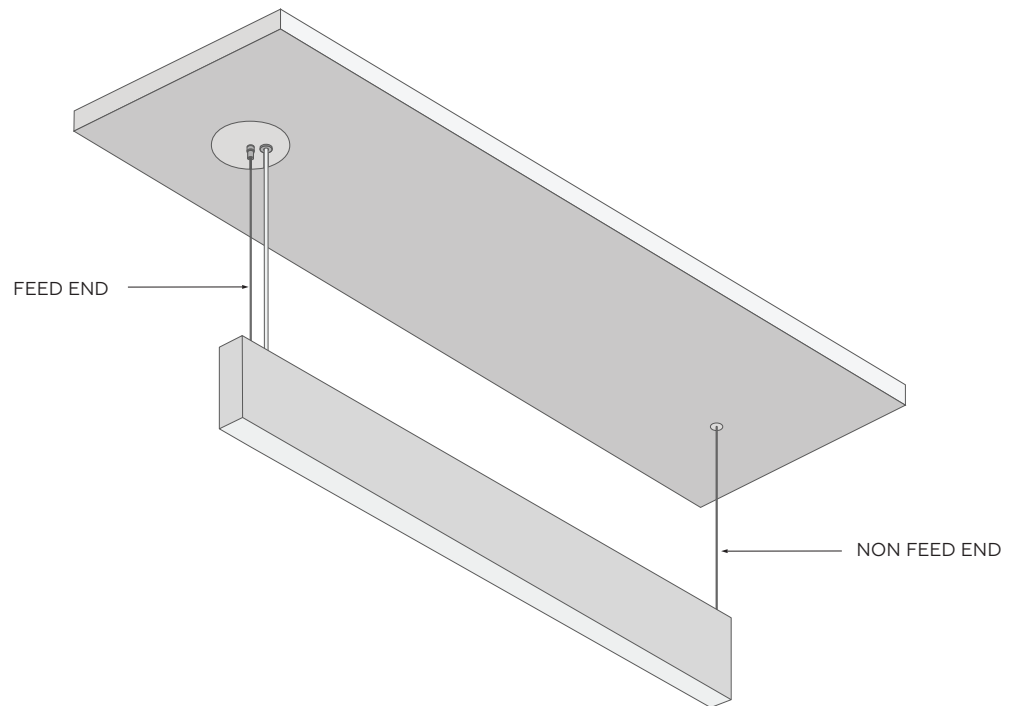



INSTALLING JOIST LED

CABLE MOUNTING "ON GRID" (T1, T9, & SC)

- Joist LED intended for "On Grid" or "T-Bar Ceiling" cable mounting are to be installed with T1 (1" T-Grid), T9 (9/16" T-Grid), or SC (Screw Slot Grid) Feed and Hanger Kits. Feed and Hanger Kits are shipped in separate kitting boxes. See pages 3-5.

CABLE MOUNTING "OFF GRID" (HC & JB)

- Joist LED intended for cable mounting are to be installed with HC (Hard Ceiling) or JB (Junction Box) Feed and Hanger Kits. Feed and Hanger Kits are shipped in separate kitting boxes. See pages 6-8.

WARNING

**Be Certain To Support Joist LED Independently
Of Cables When Depressing Retainer Stem To
Avoid Damaging Baffle.**

Figure 1

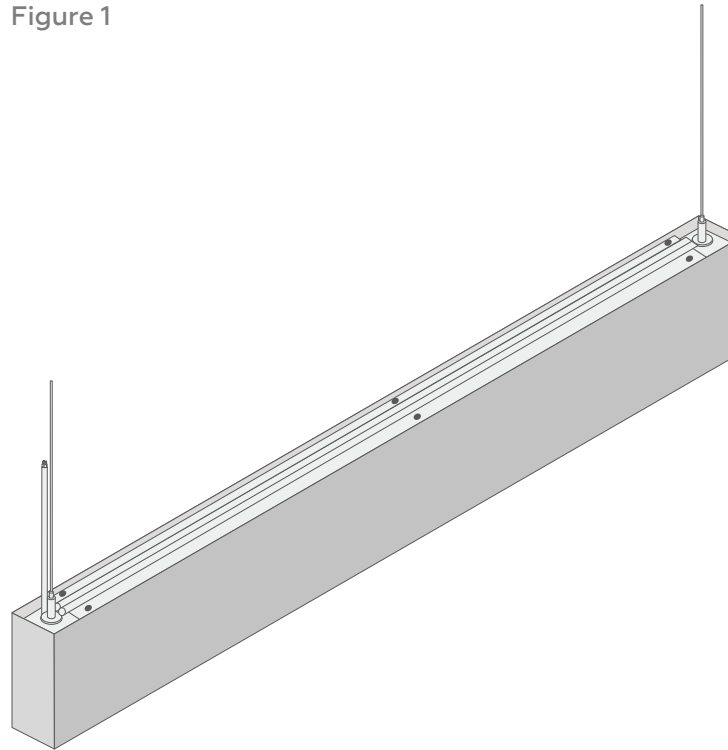



INSTALLING JOIST LED

NON-FEED CABLE/CANOPY ASSEMBLY

1. Determine mounting centers from factory shop drawing or order processing specification sheet.
2. Installation of IDS clip onto T-BAR at appropriate locations. See Step 1 & Figure 2.
 - A. Assemble 1/4"-20 stud and clip. Start stud into recessed square hole, grasp clip in hand and depress TAB A with thumb. Pull stud into place and release TAB A.
 - B. Separate clip into two parts by bending at TAB B.
 - C. Place PART X on T-BAR and insert base tab on part into slot. Close PARTS X and Y together locking with TAB C.
3. Secure IDS clip to structural support above with minimum #12 gauge support wire in accordance with local, state, and federal codes. See Figure 3.

4. Insert cable supplied in kit through ceiling coupler in kit and attach to 1/4"-20 stud on IDS clip securely. Remove threaded canopy support ring from coupler and slide canopy then support ring over cable and up to finished ceiling line. Tighten support ring to secure canopy in place.
5. Raise baffle to cable assembly and route cable through the center of the adjustable cable fitting, loosening the locking cap enough to allow cable to enter fitting. Feed cable through the adjustable fitting until desired mounting height is attained. Baffle will be retained at the last point of adjustment. Tighten locking cap onto retainer stem.

NOTE: If it becomes necessary to re-adjust Joist LED height, loosen locking cap and depress retainer stem while adjusting to desired position.

Figure 2

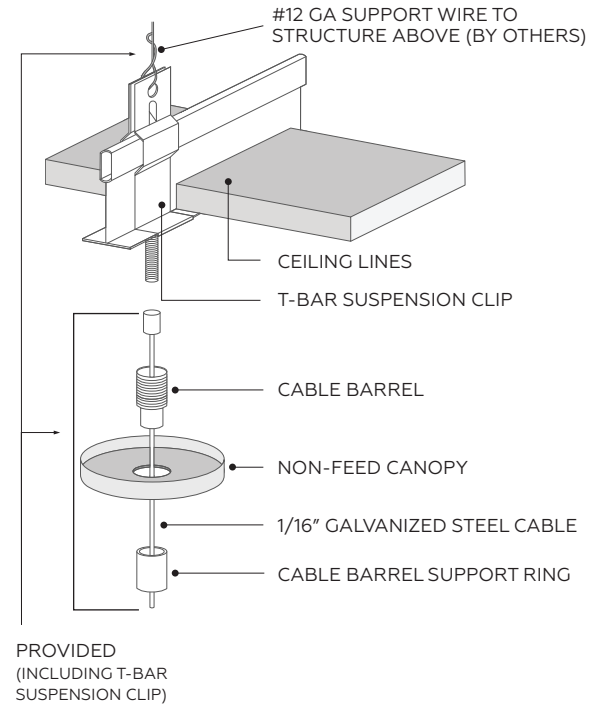
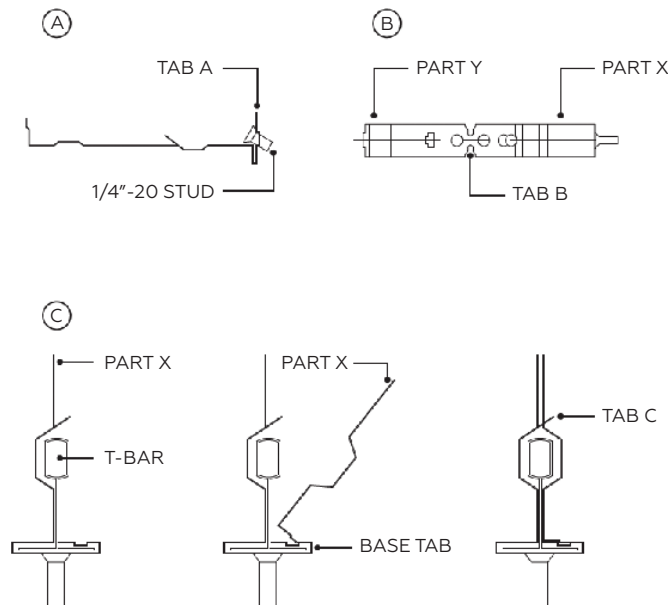



INSTALLING JOIST LED

FEED CABLE/CANOPY ASSEMBLY

1. Determine mounting cable spacing centers from the Fixture Row Layout Pages 5 - 7.
2. Install 4" Drop Ceiling Junction Box (by others) over T-BAR (by others). Align the bottom edge of the Junction Box with the ceiling. Connect the conduit from the building power to the Junction Box. Attach the Cross Bar to the Junction Box.
3. Insert the 1/16" steel cable supplied in the kit through the Coupler in the kit. Remove threaded Canopy Support Ring from Coupler. Attach Coupler to ¼-20 stud on Cross Bar securely.
4. Remove the threaded Canopy Support Ring from Coupler. Slide 5" Canopy then Support Ring over the Coupler up to finished ceiling line. Tighten support ring to locate canopy in place.
5. Raise Joist LED to mounting/feed assembly and route the 1/16" steel cable through the center of the Adjustable Cable Gripper fitting loosening the locking cap enough to allow the 1/16" steel cable to enter fitting. Feed the 1/16" steel cable through the Adjustable Cable Gripper fitting until the desired mounting height is attained. The baffle will be retained at the last point of adjustment. Tighten Locking Cap onto retainer stem.

NOTE: If it becomes necessary to re-adjust baffle height, loosen locking cap and depress retainer stem while adjusting to desired position.

CAUTION

Be Certain To Support Joist LED Independently Of 1/16" Steel Cables When Depressing Retainer Stem.

6. SJT Cord comes installed on Fixture from the factory. Route feed power cord(s) from Joist LED through the hole(s) in the canopy. Make wire connections within Junction Box with appropriate connectors and install Strain Relief as illustrated. Attach supplied tie straps around feed cord and cable at a minimum of 12" on center.

ENERGIZE AND CHECK FOR PROPER OPERATION.

FIGURE 3 ON NEXT PAGE



INSTALLING JOIST LED

Figure 3

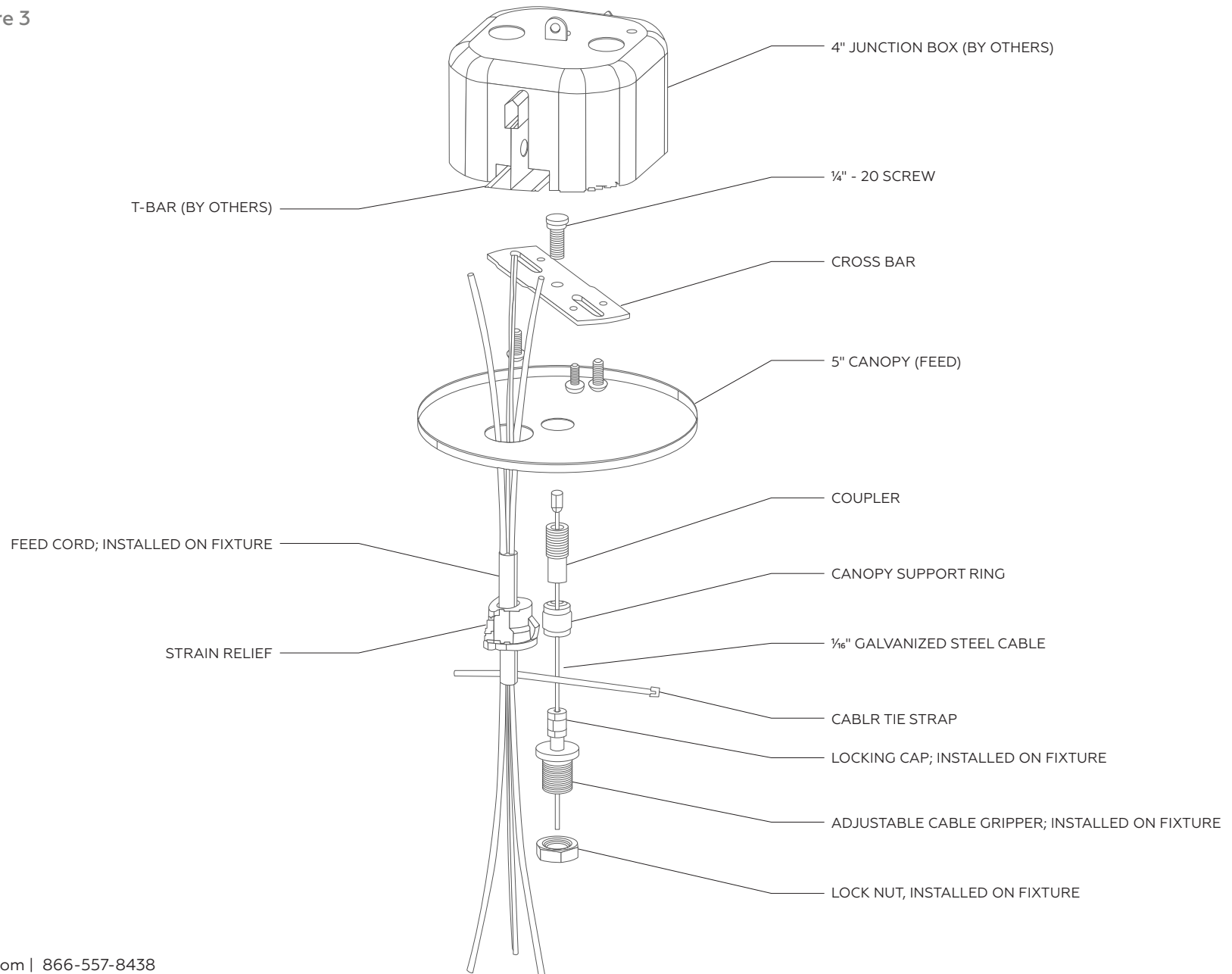



INSTALLING JOIST LED

NON-FEED CABLE/CANOPY ASSEMBLY

1. Determine mounting cable spacing centers from factory shop drawing or order processing specification sheet.
2. Install 1/4"-20 studs projecting from the finished ceiling line 1/2".
3. Insert cable supplied in kit through ceiling coupler in kit and attach to 1/4"-20 stud securely. Remove threaded canopy support ring from coupler and slide canopy then support ring over cable and up to finished ceiling line. Tighten support ring to locate canopy in place.
4. Raise baffle to cable assembly and route cable through the center of the adjustable cable fitting loosening the locking cap enough to allow cable to enter fitting. Feed cable through the adjustable fitting until desired mounting height is attained. Joist LED will be retained at the last point of adjustment. Tighten locking cap onto retainer stem.

Note: if it becomes necessary to re-adjust baffle height, loosen locking cap and depress retainer stem while adjusting to desired position.

WARNING

Be Certain To Support Joist LED Independently Of Cables When Depressing Retainer Stem To Avoid Damaging Baffle.

Figure 2

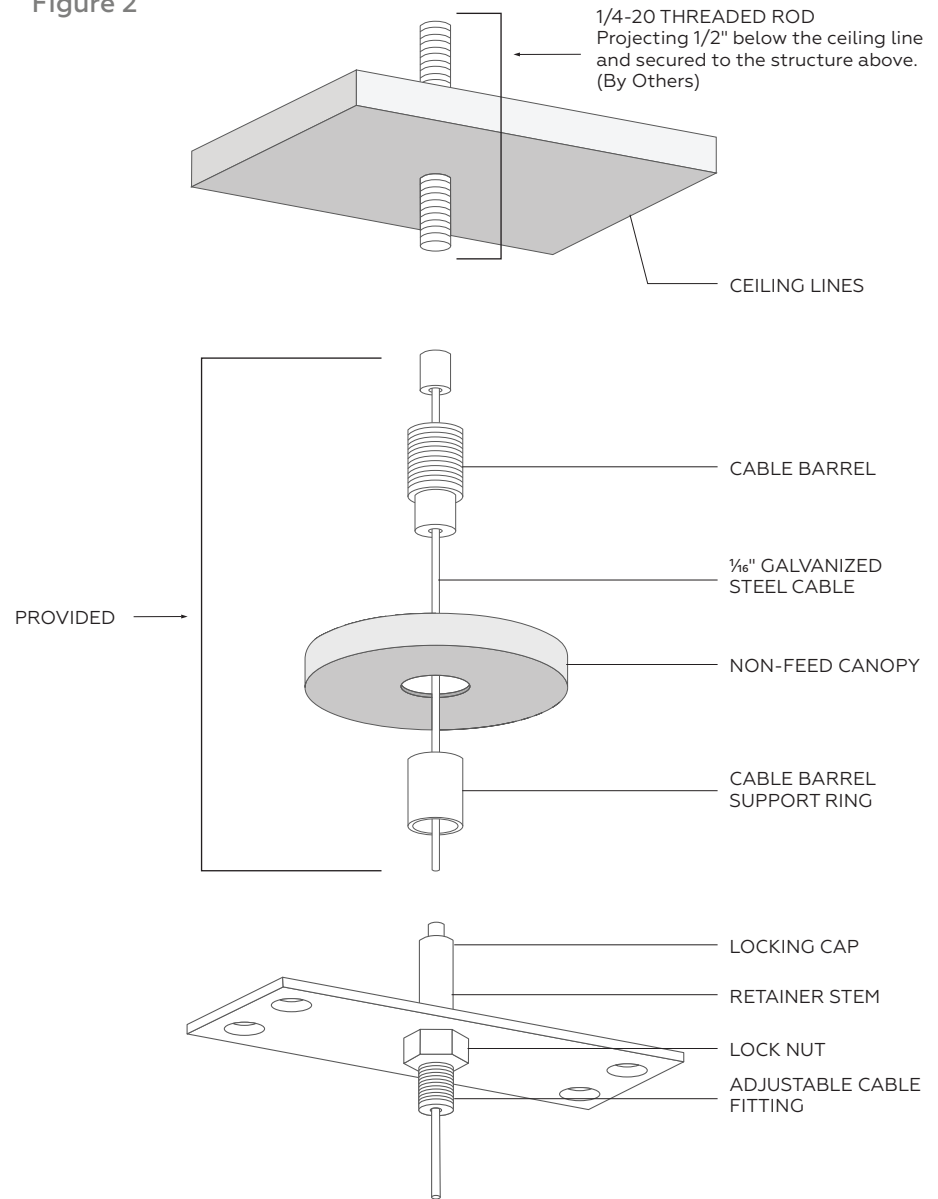



INSTALLING JOIST LED

FEED CABLE/CANOPY ASSEMBLY

1. Determine mounting cable spacing centers from factory shop drawing or order processing specification sheet and locate a 4" octagonal junction box at location indicated for incoming wire feed point.
OPTION 1: Install cross strap support bracket to junction box with screws by others. Be sure junction box can support Joist LED in accordance with local codes as illustrated.
OPTION 2: Drill a 5/16" dia hole in the roof of the junction box. Position and secure a 1/4-20 threaded rod (by others) to structural support above so that it passes through the hole drilled in the junction box and extends 1/2" below the finished ceiling line.
2. Insert cable supplied in kit through ceiling coupler in kit and attach to 1/4-20 stud securely. Remove threaded canopy support ring from coupler and slide canopy then support ring over cable and up to finished ceiling line. Loosely tighten support ring to locate canopy in place. (REF. FIG 5)
3. Raise baffle to cable assembly and route cable through the center of the adjustable cable fitting loosening the locking cap enough to allow cable to enter fitting. Feed cable through the adjustable fitting until desired mounting height is attained. Joist LED will be retained at the last point of adjustment. Tighten locking cap onto retainer stem. (REF. PAGE 9)
4. Remove canopy support ring and route feed cord from baffle through grommets hole in canopy and into junction box. Connect feed cord to incoming power feed wires within j-box with appropriate connectors and install cord restraint as illustrated.
5. Raise canopy up to finished ceiling line and locate with canopy support ring. Attach supplied tie straps around feed cord and cable at minimum of every 12".

NOTE: If it becomes necessary to re-adjust baffle height, loosen locking cap and depress retainer stem while adjusting to desired position.

ENERGIZE AND CHECK FOR PROPER OPERATION.

FIGURE 5 ON NEXT PAGE



INSTALLING JOIST LED

Figure 5

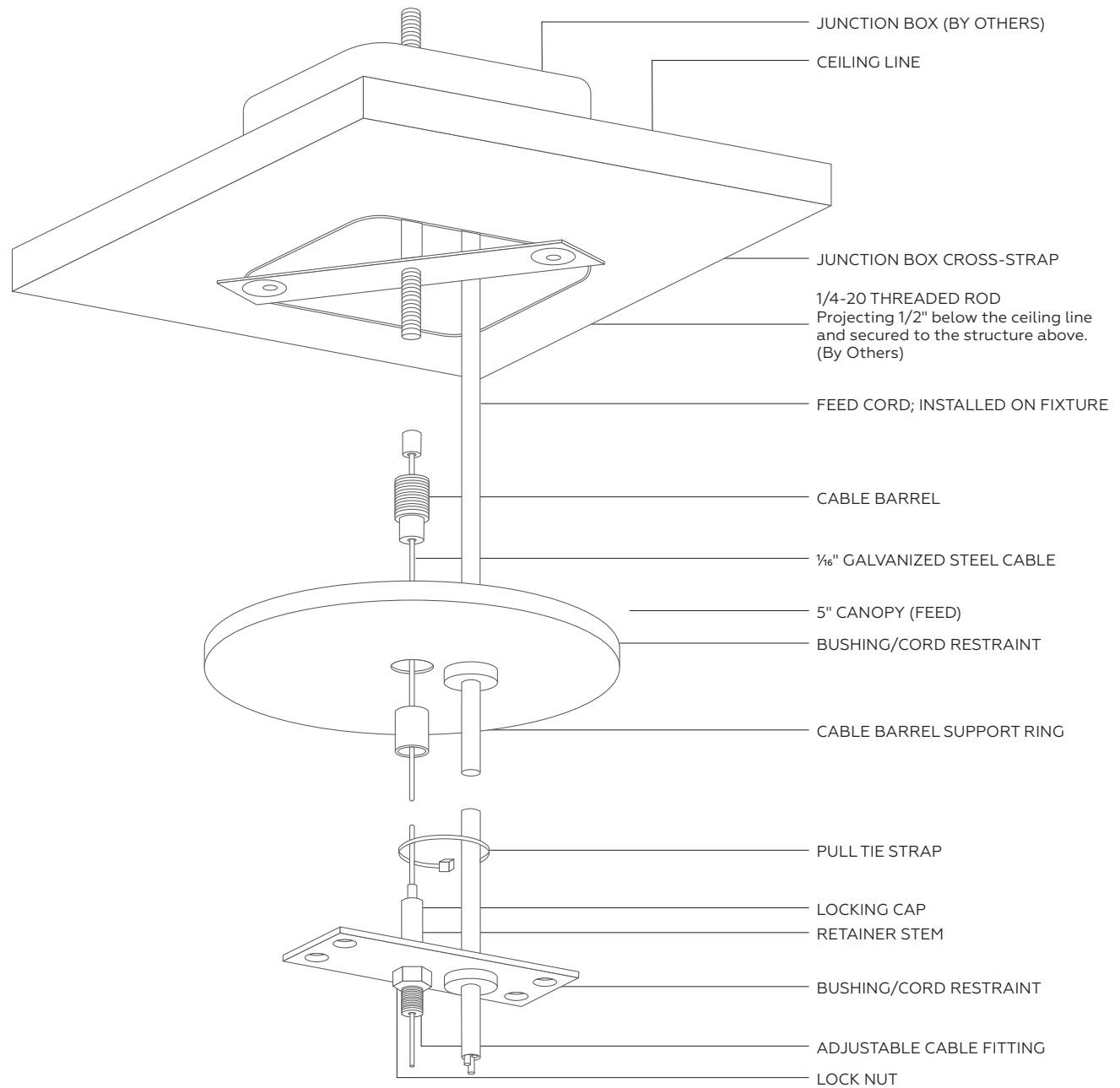



INSTALLING JOIST LED

INDIVIDUAL FIXTURE INSTALLATION

1. Locate and remove fixture from packaging.
2. Locate the suspension cable locations as shown in the specification sheet (view Spec Sheet), suspend the fixture by feeding the 1/16" galvanized steel cable through each cable gripper. Move and level the fixture to specified position and tighten the cable gripper nut to lock the 1/16" steel cable.
3. Cut off excess aircraft cable with side cutters or similar.
4. Leave approximately 1/2" for minor adjustments. (REF. FIG 7)
5. Fixture Identification and electrical ratings are on a label located behind the direct lens. To access these labels, use a flat tool or card to pry off the direct lens at the power entry side's end-cap.

ENERGIZE AND CHECK FOR PROPER OPERATION.

Figure 6

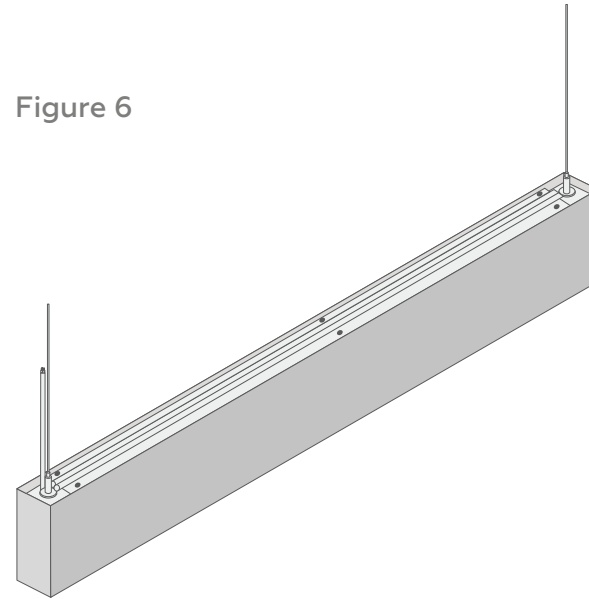

Figure 7

