



RUMUR

felt wall



INSTALLATION GUIDELINES

TOOLS REQUIRED



Cutting tool



Steel straightedge



Drill



Hole saw



Construction adhesive

DRY FIT

Before applying adhesive, dry fit the first panel to the wall.

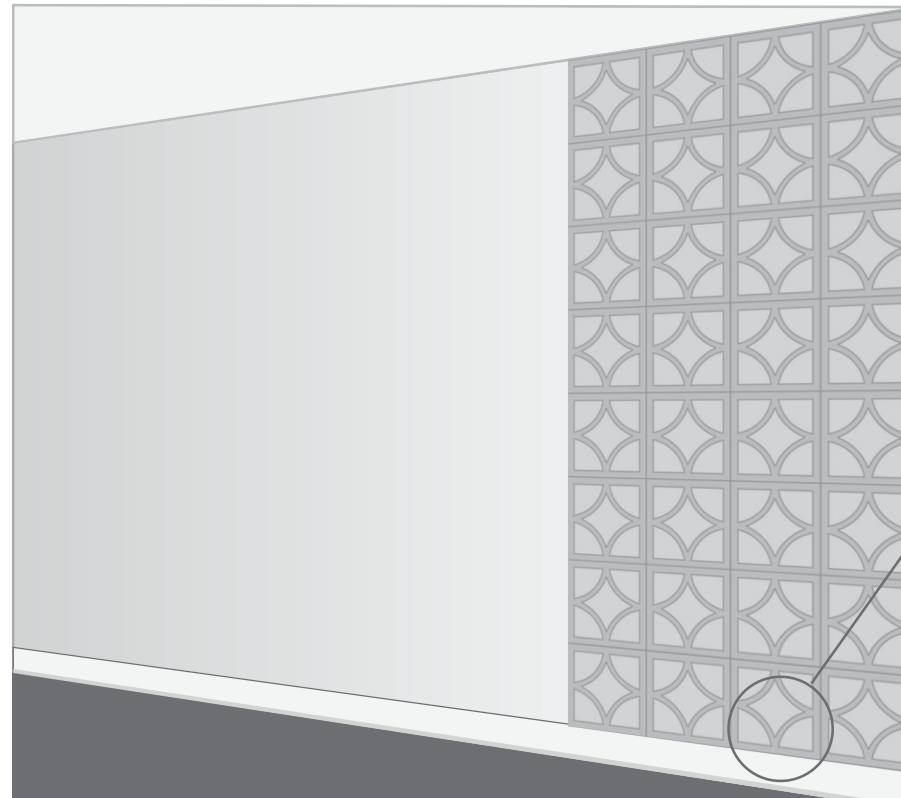

Note: to avoid irregularity, we recommend applying to the top of a baseboard.



INSTALLING RUMUR

APPLY CONSTRUCTION ADHESIVE (RECOMMENDED)

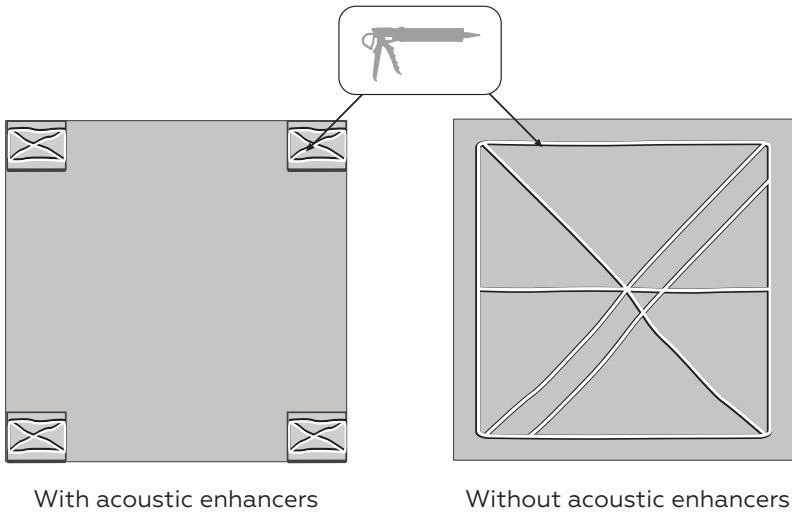

ACOUSTIC
ENHANCERS

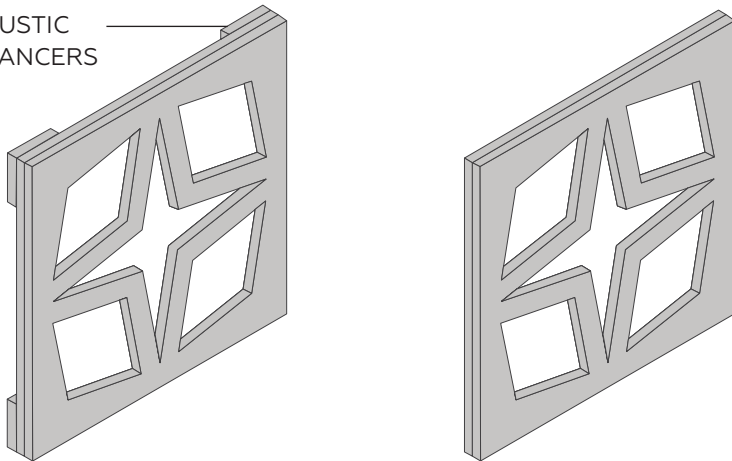

HOOK Z-CLIPS (ALTERNATIVE)

Determine the desired position of z-clips and screw them into the back of the panel.

